

35 Pickup Tones with T3Plus-Switch (also S3 Switch)

T3Plus-Switch Legend (switch information)

Pickup Phase Switches:

SW1, SW2, SW3 are on-off-on Phase switches

Each switch controls one pickup coil in normal phase (Down) or reverse phase (Up) The Center position of the switch is Off

SW1 Controls the Bridge Pickup (coil #1)

SW2 Controls the Middle Pickup (coil #2)

SW3 Controls the Neck Pickup (coil #3)

Pickup Connection Switches:

SW4, SW5, SW6 are on-on Connection switches

These three switches are Down by default (to put all pickup coils in parallel connection)

When **SW4** is Up (puts coils 1 & 2 in series)

When **SW5** is Up (puts coils 1 & 3 in series)

When **SW6** is Up (puts coils 2 & 3 in series)

When **SW4 & SW6** Up (puts all coils in series)

ALL pickup coils that are in series MUST be on to produce sound.

© 2011 AweSome Musical Instruments, All rights reserved worldwide
www.awesome-guitars.com

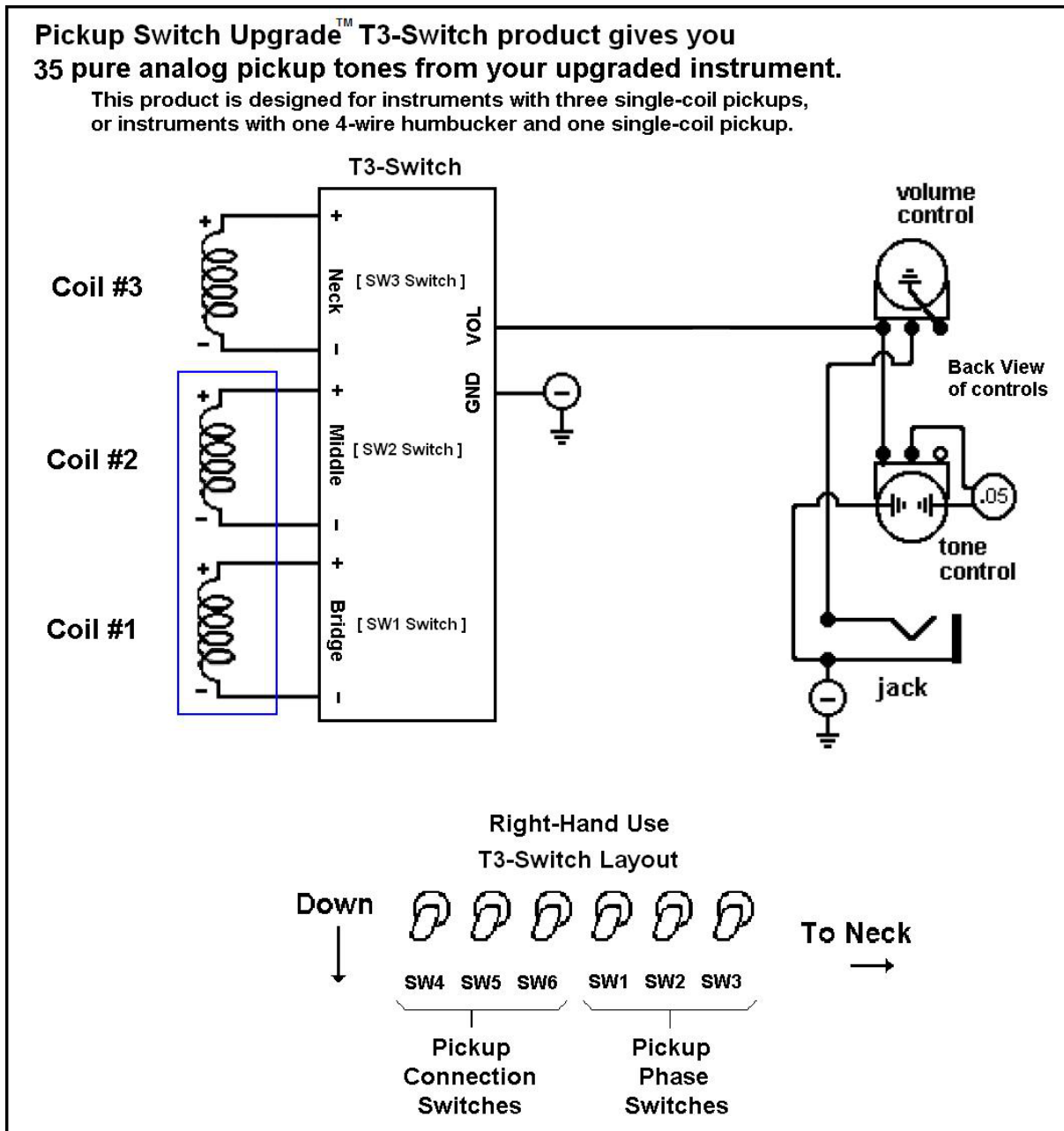

Switching Proof Table to get 35 pickup tones with T3Plus-Switch from instruments with three single-coil pickups, or instruments with one 4-wire humbucker and one single-coils.

Switch legend for **SW1, SW2** and **SW3**: D = Down, U = Up, no symbol is Off (center position)

Switch Legend for **SW4, SW5** and **SW6**: U = UP, no symbol is Down

The following switch numbers will give you the stock 5 Stratocaster pickup tones.

1-Bridge, 4-Bridge+Middle (Parallel), 2-Middle, 8-Neck+Middle (Parallel), 3-Neck

(Fav-1/2/3 are your favorite pickup tones)

SWITCH COMBINATIONS USED BY T3PLUS-SWITCH

| ## | SW3 | SW2 | SW1 | SW6 | SW5 | SW4 |
|-------|-----|-----|-----|-----|-----|-----|
| Fav-1 | --- | --- | --- | --- | --- | --- |
| Fav-2 | --- | --- | --- | --- | --- | --- |
| Fav-3 | --- | --- | --- | --- | --- | --- |
| 1. | | | D | | | |
| 2. | | D | | | | |
| 3. | D | | | | | |
| 4. | | D | D | | | |
| 5. | | U | D | | | |
| 6. | D | | D | | | |
| 7. | U | | D | | | |
| 8. | D | D | | | | |
| 9. | U | D | | | | |
| 10. | D | D | D | | | |
| 11. | U | D | D | | | |
| 12. | D | U | D | | | |
| 13. | U | U | D | | | |
| 14. | | D | D | | | U |
| 15. | | U | D | | | U |
| 16. | D | D | D | | | U |
| 17. | D | U | D | | | U |
| 18. | U | D | D | | | U |
| 19. | U | U | D | | | U |
| 20. | D | | D | | U | |
| 21. | U | | D | | U | |
| 22. | D | D | D | | U | |
| 23. | U | D | D | | U | |
| 24. | D | U | D | | U | |
| 25. | U | U | D | | U | |
| 26. | D | D | | U | | |
| 27. | U | D | | U | | |
| 28. | D | D | D | U | | |
| 29. | U | D | D | U | | |
| 30. | D | D | U | U | | |
| 31. | U | D | U | U | | |
| 32. | D | D | D | U | | U |
| 33. | U | D | D | U | | U |
| 34. | D | U | D | U | | U |
| 35. | U | U | D | U | | U |

Your description of the pickup sound

Fav-1 _____

Fav-2 _____

Fav-3 _____

1. _____

2. _____

3. _____

4. _____

5. _____

6. _____

7. _____

8. _____

9. _____

10. _____

11. _____

12. _____

13. _____

14. _____

15. _____

16. _____

17. _____

18. _____

19. _____

20. _____

21. _____

22. _____

23. _____

24. _____

25. _____

26. _____

27. _____

28. _____

29. _____

30. _____

31. _____

32. _____

33. _____

34. _____

35. _____