

Before you start, **read these instructions first** to understand what you need to do to install this product.

## Assumptions

This upgrade product is designed to use only one Volume and one Tone control for your instrument's pickups. It is designed to control 2 magnetic pickup coils. **Your single-coil pickups must have 2 wires.**

**Note:** *Active* (uses batteries) or *Pizeo* pickups cannot be used with this product.

## Tools Needed

You may need one or more of the following tools (not included with purchase) to install this upgrade.

- Wire cutters / Wire strippers
- Regular pliers
- Small Phillips & straight slot screwdriver (a 4-way screwdriver can be used as a deep-well socket to loosen switch mounting nuts.
- Ohmmeter to measure continuity
- Optional: rotary file and electric drill
- Optional: Soldering iron (25/30 watt max.) with fine tip, rosin-core solder .022" dia.

## Preamble

Although not required for this product, you might want to completely **remove all strings** from your instrument for easy access to its parts. The strings are probably already old and replacing them will make your instrument sound even more *brilliant* after you install this product.

This upgrade will have you cutting existing wires on your instrument. You may need to make wire connections, increase the length of existing wires, and remove some wood in your instrument body cavity.

Because you will be making several changes to your instrument, you need to have a plan to install this upgrade product.

See the *Reference Drawing* on a later page of this document. Use a pencil to draw the original circuit of your instrument **before** you proceed. When you record where the wires (and colors) were removed from your instrument, you have a way to restore it to its original condition should it become necessary. Since there is a large variation of pickup switch wiring that spans 50 years, you will need to draw your own pickup switch used in your original circuit

## Adding Extra Wire

If your pickup wires are too short to easily reach the specified connection of the green terminal strip on the switch circuit board, here is what to do. Measure out the needed length of the RED or BLACK wire in the included **PARTS BAG** to permit the wire to reach the applicable connection. A length of 3" (7.62cm) is budgeted for each wire extension. Insert the **unstripped** end of each wire into the 2-wire UY2 **yellow/clear** connector top button and **firmly** squeeze down the top button using regular pliers so it is flush with the body to create a permanent electrical connection. Verify electrical continuity between the two pickup wires using an ohmmeter (some coil resistance will be present).

**Note:** If either of your pickup wires use a shielded /braided cable, you will need to solder black wire to the cable because the green terminal strip (J1) does not directly accept shielded cable.

# TELECASTER THINLINE SS UPGRADE

You have received an assembled and tested upgrade designed for your Fender Telecaster Thinline SS guitar. It contains a T2-Switch and one tone and volume control with matching knobs. No soldering is needed to install this product. You will use your own pickups. The following items are included in a Parts Bag.

- Several business cards to pass out to friends
- An equal length each of black and red insulated wire (*to lengthen pickup wire if needed*)
- 2 yellow/clear connectors (UY2) to make pickup wire extension connections if needed
- 2 grey wire nuts to connect the upgrade wires to your instrument output jack

## Preparation

If needed, remove your strings. Remove your existing pickguard or control plate attaching screws. Lift it out and document how your instrument is wired (see *Preamble* on page 1) *before* you start this upgrade.

Cut the **pickup wires** from the 3-way pickup switch so all wires are of maximum length. If needed, disconnect the bridge ground wire. Remove your original pickguard or control plate and store it in a safe place. Temporarily stow the pickup wires within the body cavity.

**Special Note:** Your Bridge pickup must have two wires to successfully install this upgrade.

Confirm that the Upgrade product will lay completely flat and within the routed body cavity with no interference by the wood body. If the Upgrade lays flat on your instrument and the plate mounting holes line up with the body mounting holes, proceed to the next section, *Terminal Strip*, to continue with the upgrade process.

If your Upgrade mounting holes and body mounting holes do not line up, or you have a pickguard or control plate body cavity with a non-standard dimension preventing the upgrade product from being installed, see *page 7 – Solving Installation Issues* for information that identifies how to easily resolve these issues.

Remove the neck pickup from the stock pickguard and install it into the upgrade.

## Terminal Strip

Here is how to attach wires to the **green** terminal strip (J1) that is on the T2 Switch circuit board. Use a small screwdriver or writing pen tip and press down on the square *release button* located directly above the wire hole. Hold the button down and insert the stripped wire completely into the wire connection hole and then release the button. Lightly tug on the wire to confirm it is firmly gripped by the Terminal Strip. A legend is printed on the circuit board with the name of each terminal strip wire hole from left to right. Attach each wire to the correct terminal strip hole. In all instances, the **GND** and **VOL** wires from the Volume/Tone control circuit displayed on page 3 to the wire connection holes on the terminal strip are already connected.

**T2-Switch (6-hole terminal strip):** [GND] [VOL] [+]Coil-2[-] [+]Coil-1[-]

**Caution:** Do not insert hard items in the wire holes because it will decrease reliable electrical connection.

## Connecting Your Wires

There is no industry standard for pickup wire lead colors. More common color pairs are red/black, red/white, black/white and white/shield. You are advised to use consistency when connecting *your* pickup wire color pairs to the [ + ] and [ - ] pickup connections on the green terminal strip (J1).

Determine which wire color for each pickup coil will be attached to the applicable [ + ] and [ - ] green terminal strip connector on our T2 switch. If one of the pickup wire connections is a shielded lead, always connect the shield to a BLACK [ - ] wire to be inserted in the green terminal strip on our switching system.

Determine if there is enough wire length from each 2-wire pickup to *comfortably* reach the corresponding connectors on the green terminal strip of the circuit board of this upgrade product. If not, refer to the “*Adding Extra Wire*” topic (page 1). Also note that if you add extra wire using the UY2 connectors, you **MUST** use an ohmmeter to confirm the connection is electrically sound. If not, press the buttons on the UY2 connectors more firmly until electrical continuity is established.

**WARNING:** If your pickups have a metal bottom and if either pickup coil wire is grounded to this housing (use an ohmmeter to check each wire to body), make sure your instrument’s body cavity is not lined with grounded metal shielding and the pickup housing does not have a separate grounding wire.

**Reason:** This will cause the pickup to “short” to ground when the pickup switch is put into the regular/reverse phase. To fix this, isolate the pickup housing from the body cavity shielding with soft foam.

Strip off 3/16” (4.76mm) insulation from the end of each pickup wire then twist the exposed wire strands so they are tightly bound. If you have a soldering iron, it will be helpful to lightly “tin” the wire strands so they do not unravel. Insert the wires of each pickup pair into the correct location on the green terminal strip (J1) using the process described in the above “*Terminal Strip*” topic. Attach the wires using the instructions on the following page.

**Note:** If you have a ground wire coming from the bridge (and maybe from body cavity shielding), connect these wires to ground lead on the input jack.

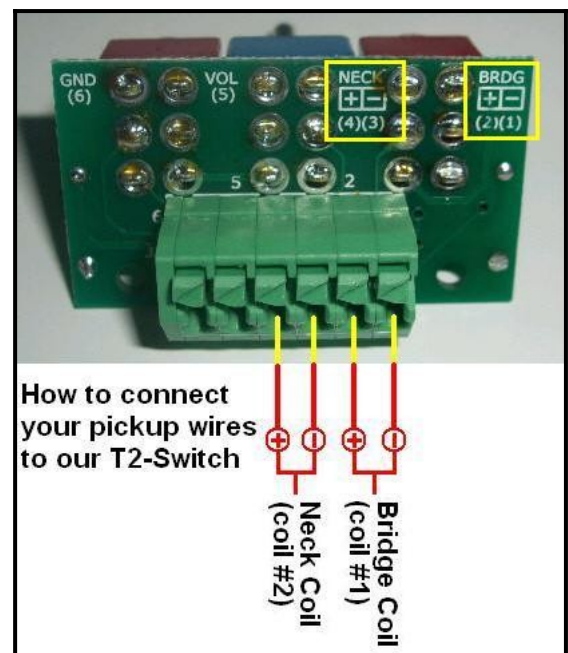

## Connecting your pickups to the Upgrade

Connect your **NECK** pickup coil wire pair to the [ + ]<sub>Coil-2</sub>[ - ] connections on the green terminal strip  
Connect your **BRIDGE** pickup coil wire pair to the [ + ]<sub>Coil-1</sub>[ - ] connections on the green terminal strip

## Upgrade Switch Identification and Use Summary

Here is a summary of switch use for this product (see **Figure 1** for switch identification).

A complete *Switch Table* contains more details about how the switches are used for each product. It is available for download from our website's Document Library at <https://www.AweSome-Guitars.com>

SW1 and SW3 are ON-OFF-ON switches that turn on individual pickups in normal or reverse phase  
SW5 is an ON-ON switch that changes the pickups from *Parallel* to *Series* connectivity

### For a Right-Handed Instrument:

SW1 turns On the **bridge** pickup, either in normal phase (down), or reverse phase (up).

SW3 turns On the **neck** pickup, either in normal phase (down), or reverse phase (up).

SW5 When this switch is **down**, the pickups will be in a *Parallel* circuit.

When this switch is **up** it puts the **bridge** and **neck** pickups in a *Series* circuit.

**Special Note:** When this switch is up, both pickups must be On, either in normal phase (down) or reverse phase (up) or no sound will be produced.

Your upgrade now includes colored switch covers for easy use. The White covers are on the switches that turn a pickup coil On and Off. The Black covers are on the switches that put the applicable pickup coils in Parallel or Series. (*remove them if not needed.*)

## Validating

Connect your instrument to an amplified source with the volume set to low. If your instrument has no strings, simply turn the switches on and off as described in “*Switch Identification and Use Summary*” topic while gently tapping the magnet of the pickup coil that should be “on” with a small screwdriver to confirm pickup response. Also confirm the correct operation of the Volume and Tone controls.

If you receive the stated results, install the upgrade mounting hole screws. Next, install a new set of strings. Welcome to the *Grand Canyon Wide* range of AweSome pickup tones provided by our upgrade product.

This product is designed to give your 2-pickup instruments a significant spectrum of additional pickup sounds. Please keep in mind that the pickup tones you get are as a result of the existing pickups that are in your instrument. If you replace one of the pickups with another pickup that has a different characteristic (*such as a different coil impedance or different magnet type*), you will experience a completely different “palette” of pickup tones. This product will produce several unique pickup sounds.

## Figure 1 – Switch Identification

The following images identify each of the switches and use for this upgrade.

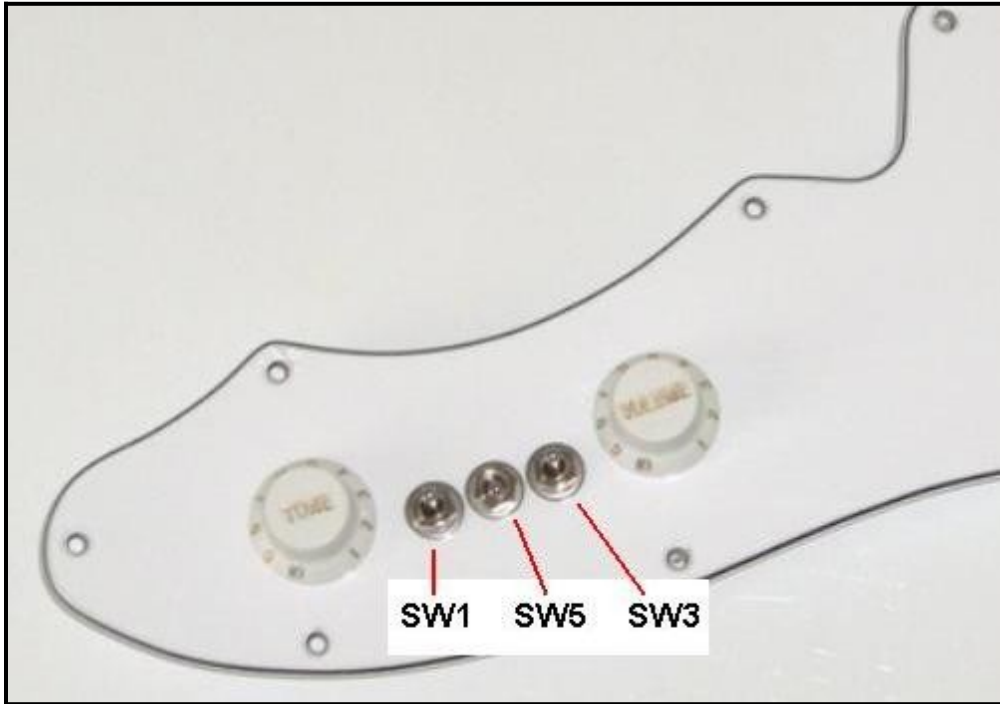

## Figure 2 – Reference Drawings

Use the following image to document your instrument's original wiring. Be sure to identify wire colors where needed. Use a pencil when doing this. You need to draw the pickup switch in your instrument.

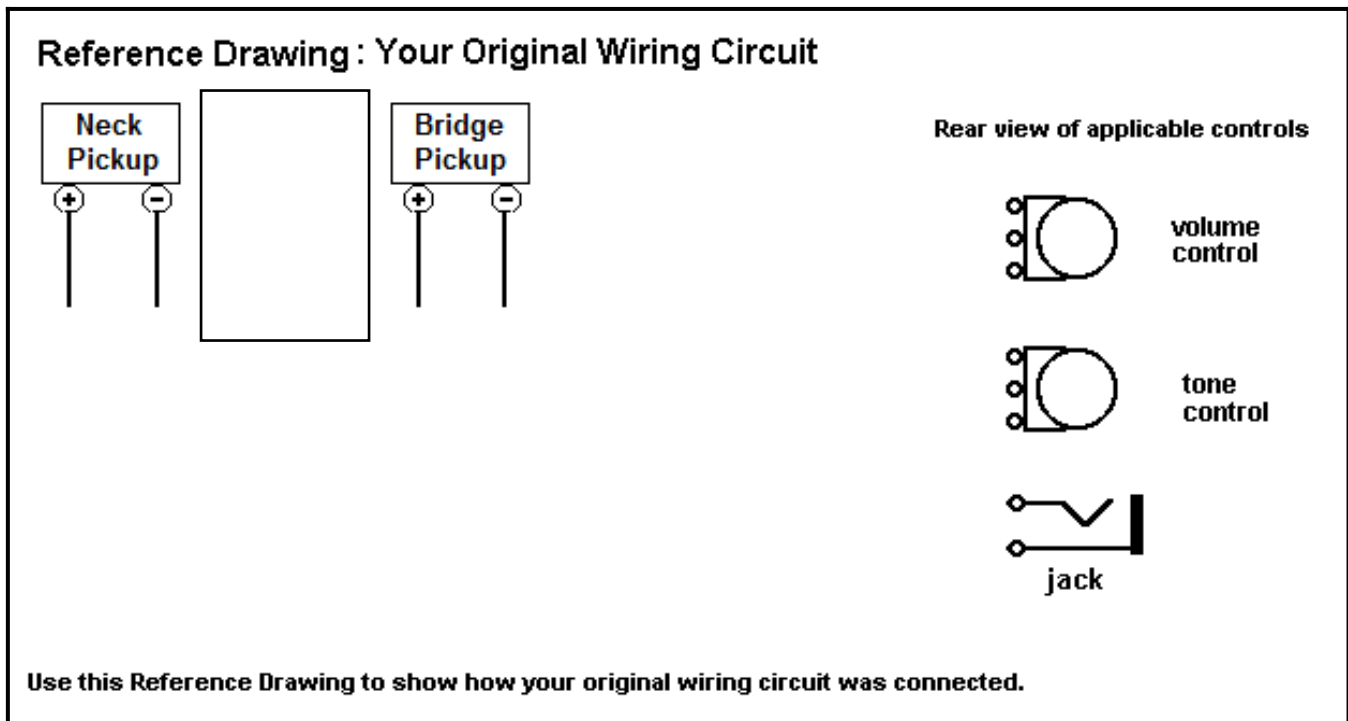

### Figure 3 – Pickup Connection Details

The following drawing identifies where to connect your pickups to this upgrade product. The Upgrade includes our VT-2 products that are only available in Right-Hand audio taper.

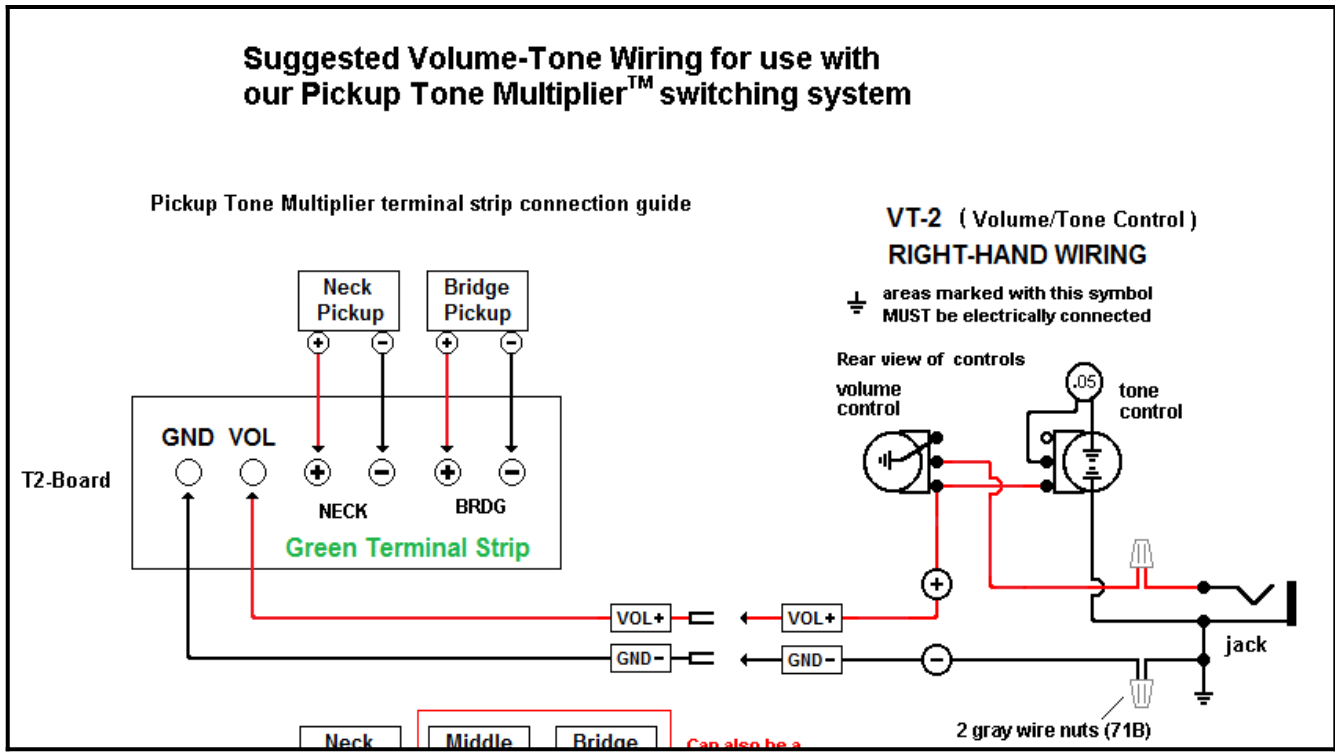

## Solving Installation Issues

Here is how to solve installation issues that involve insufficient body cavity width and/or depth.

1. The mounting holes for the Upgrade do not line up with the body mounting holes.

It may be necessary to drill new mounting holes.

2. The Upgrade does not fit into the body cavity because of there is not enough room.

To solve these body cavity width and depth issues, you can use a power drill with a rotary file to remove a small amount of material on either side of the body cavity. You should only remove enough material to permit installation.

The illustrations (below) identify how to use the electric drill and rotary file bit to remove excess material on each side of the body cavity. Also illustrated are two common rotary file bits. The top one is a rasp bit, the lower one is a scraping bit. Either will work.

When using this procedure, it is recommended that you enlist the help of a friend to firmly hold the guitar body while removing the unneeded wood using the rotary file. Using a blanket or other material between the guitar body and the working surface will prevent the bottom of the body from being scratched.

